

EWELLIX

MAKERS IN MOTION

Solutions for Aerial Work Platforms



The heritage of innovation

Ewellix is a global innovator and manufacturer of linear motion and actuation solutions used in assembly automation, medical applications and mobile machinery. Formerly part of SKF Group, the Ewellix Group consists of 16 sales units and eight factories. External net sales are approximately 2.3 SEK billion and we employ around 1 200 people. Ewellix is headquartered in Gothenburg, Sweden and is owned by Triton.

Technology leadership

Our journey began **over 50 years** ago as part of the SKF Group, a leading global technology provider, with the world's first precision ball and roller screw factories. Our history with SKF provided us with the **expertise to continuously develop new technologies** and use them to create cutting edge products that offer our customers a competitive advantage.

In 2019, we became independent from SKF and changed our name to Ewellix. **We are proud of our heritage.** This gives us a unique foundation on which to build an agile business with engineering excellence and innovation as our core strengths.

Global presence and local support

With our **global presence**, we are uniquely positioned to deliver **standard components and custom-engineered solutions**, with full technical and applications support around the world. The long lasting relationships with our distributor partners allow us to support customers in a variety of different industries. At Ewellix, we don't just provide products; **we engineer integrated solutions** that help customers realise their ambitions.



1250 employees



7 factories



16 sales units



2 competence centres

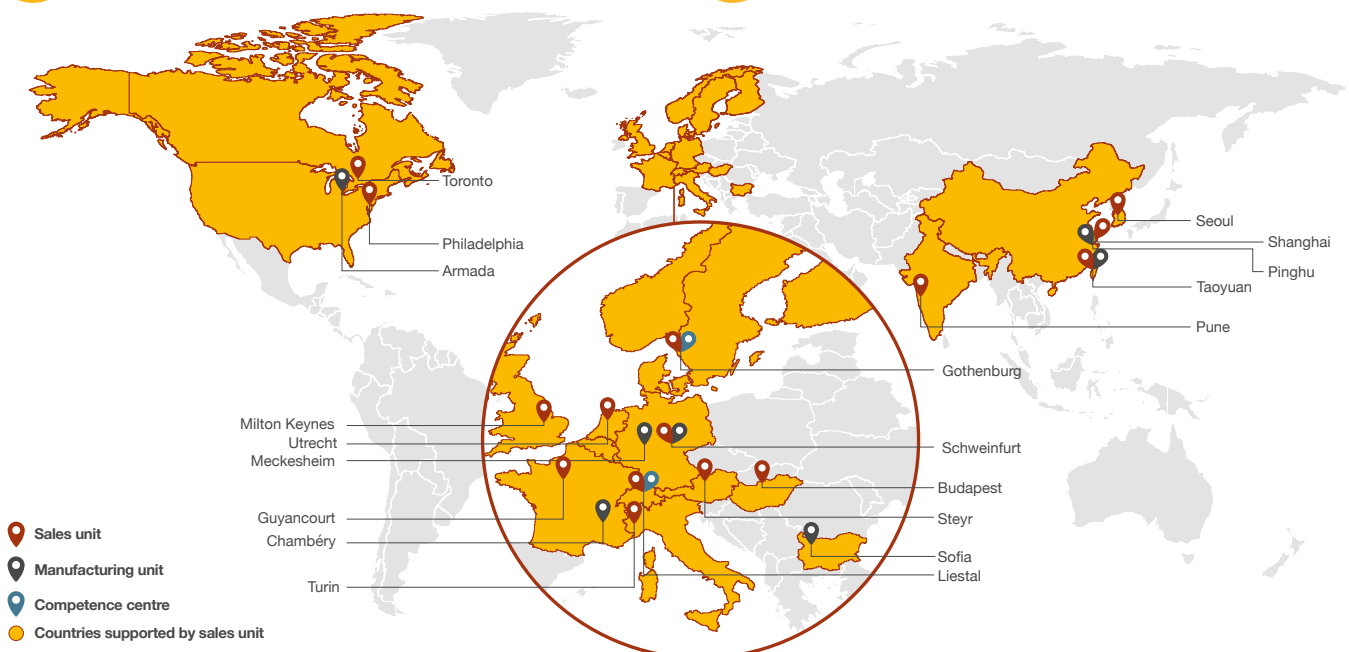

More uptime, no leakage, lower Total Cost of Ownership

Aerial work platforms are exceptionally mobile and allow operators to easily manoeuvre around tight indoor and outdoor worksites. Characterized by low noise levels, aerial work platforms provide excellent capacity and stable workspace

Critical drivers for electrification in aerial work platforms

- Legislation to reduce CO₂ emissions
- Noise emission limits in indoor operations
- Increased sustainability targets driving energy efficiency improvements

With greater efficiency and electrical power recuperation from the regenerative lowering system, electromechanical actuators optimise the cost of batteries by increasing their uptime. Better motion control and feedback will achieve greater productivity. Oil-free operation drastically reduces maintenance effort and eliminates the risk of oil leaks. All the above contributes to a decrease in the the Total Cost of Ownership.

Electromechanical advantages compared to hydraulics

Oil-free operation

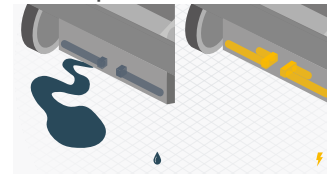

Less overhaul and maintenance



Smooth movement

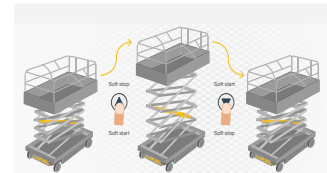

Higher uptime and quicker recharge

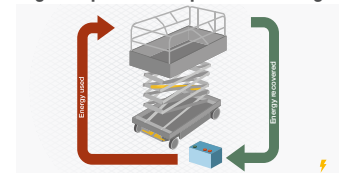

A recent survey in mobile machinery showed that over 86% of the industry agrees that electrification is an essential topic in their organisations.

Machine manufacturers recognise that even partial electrification of equipment can potentially deliver high benefits in cost, reliability and operations.

Electromechanical actuators are increasingly becoming alternatives to hydraulic systems that have dominated the mobile machinery sector for decades.

**Essential for
86% of the
industry**

Digital offer

Mobile Machinery



Battery Electric Vehicles



Scissor lift platform

Aerial work platforms and access equipment are used in different locations, but they are becoming increasingly regulated by law on construction sites in our cities and buildings. Legislation on CO₂ and greenhouse gas emissions, low emission zones, EU emissions regulations, emission limits for enclosed spaces, environmental rules and urban noise limits are key aspects that manufacturers need to consider. The trend is towards hybrid or all-electric solutions. Ewellix electromechanical actuators are strategic components in electrical solutions.

Ewellix solutions

Features

- Oil-free operation with comparable performance and power density
- Comparable attachment point and T bar
- Ball screw with back-up nut
- Electro magnetic brake and lowering device with speed control
- Allows energy recuperation
- Built-in sensor
- Built-in controller with CAN bus
- High stability
- Electrical, mechanical and climatic test performances

Benefits

- No diaper / no oil leakage risk
- Energy-efficient with less battery and recharge time
- Smooth operation with higher reliability
- Valuable data output for telematics



CASM-100



CAHB-2x series

Linear actuators

	CAHB-2x
Rated push load	up to 10 000 N
Speed	up to 57 mm/s
Stroke	up to 700 mm
Retracted length	Stroke + 160/235 mm
Static load	20 000 N

High performance actuator

	CASM-100
Rated push load	up to 82 000 N
Speed	up to 890 mm/s
Stroke	up to 2 000 mm
Retracted length	Stroke + 326 mm
Static load	82 000 N

Boom lift platform

Hydraulic lifting platforms are used in different locations, but they are becoming increasingly popular and required by law on construction sites in our cities and in buildings. The trend is towards hybrid or all-electric solutions. In addition to the lifting function, the platform rotation should also be a robust but lightweight solution as it is located at the top of the mast. The electromechanical actuators from Ewellix offer many advantages in terms of saving weight at a significant point on the mast.

Ewellix solutions

Features

- Oil-free operation with comparable performance and power density
- Comparable attachment point and T bar
- Ball screw with back-up nut
- Electro magnetic brake with patented descent system
- Allows energy recuperation
- Built-in sensor
- Built-in controller with CAN bus
- High stability
- Electrical, mechanical and climatic test performances

Benefits

- Full package drop-in replacement
- No diaper/no oil leakage risk
- Energy-efficient with less battery and recharge time
- Smooth operation with higher reliability
- Valuable data output for telematics

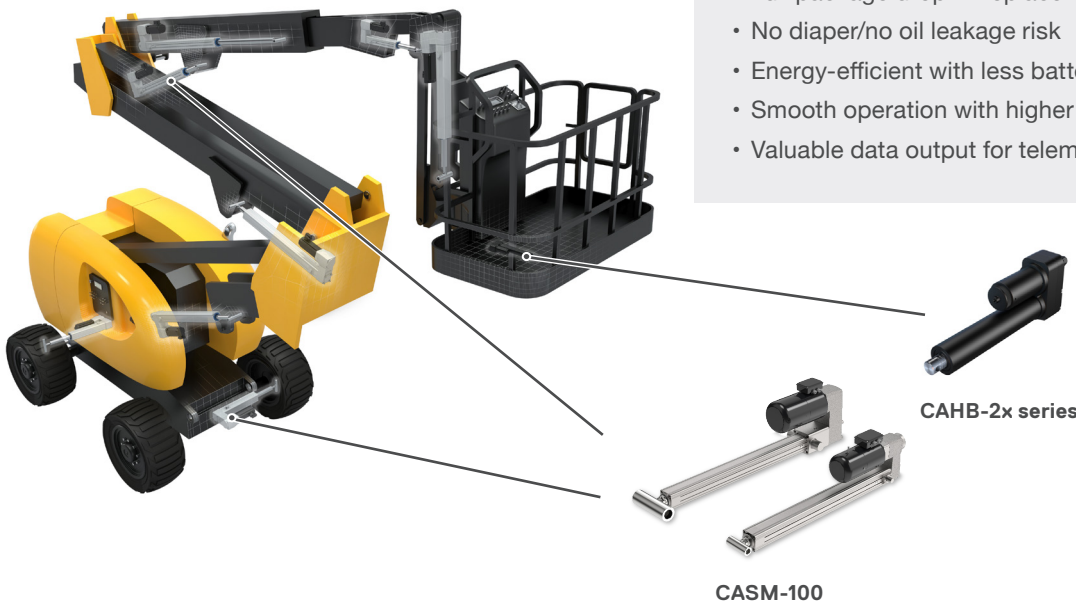

Linear actuators

	CAHB-2x
Rated push load	up to 10 000 N
Speed	up to 57 mm/s
Stroke	up to 700 mm
Retracted length	Stroke + 160/235 mm
Static load	20 000 N

High performance actuator

	CASM-100
Rated push load	up to 82 000 N
Speed	up to 890 mm/s
Stroke	up to 2 000 mm
Retracted length	Stroke + 326 mm
Static load	82 000 N

Tested for your environment

Ewellix's expertise in mechanics and electronics and specific application requirements contribute to the development of electromechanical actuators to meet the requirements of mobile machinery manufacturers. We verify our products through a comprehensive test plan that covers all regulatory and environmental requirements.

Mechanical tests

The actuators are used on mobile equipment and we put them on different test benches to validate how they withstand vibration and shock on all three axes.

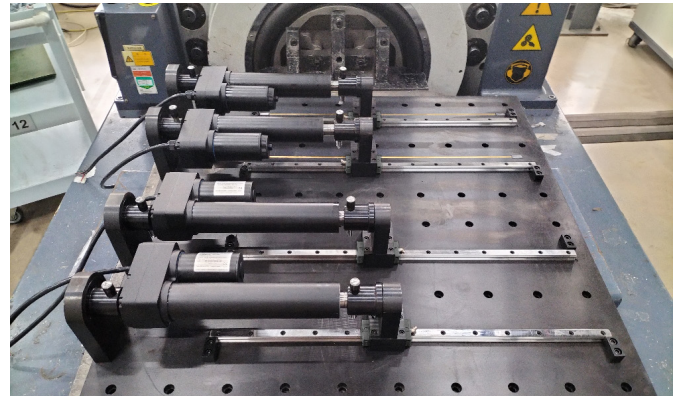

Vibration test

Climatic tests

The actuators are tested in a climatic test chamber that reproduces extremely low -40°C and high temperatures $+85^{\circ}\text{C}$ and any possible variations, including humidity and corrosive atmospheres. Doing this ensures that all the functions and performance of the actuators are working as expected.

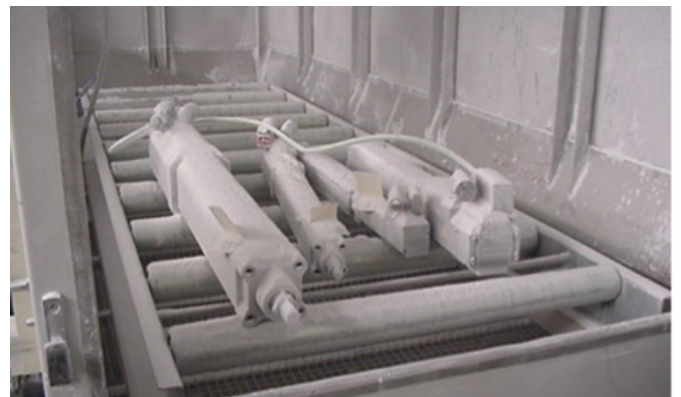

Low temperature test

Electrical tests

The actuators are tested with different test equipment that reproduces the electrical environment recommended by international standards, such as power supply, immunity to the electrostatic discharges, and electromagnetic compatibility during extreme cases, even during the transient mode typical on a vehicle.

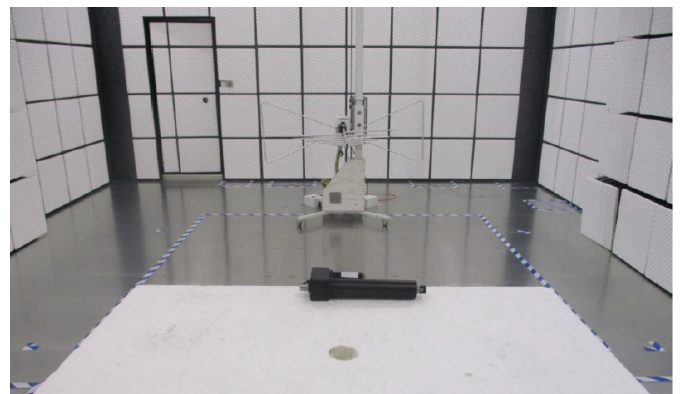

EMC test air immunity or radiation test

Supporting tools

Digital

Ewellix has developed a portfolio of tools to support customers easily select and calculate the right Ewellix product for their application.

Actuators

- Product selection
- Performance calculator
- Cost saving calculator

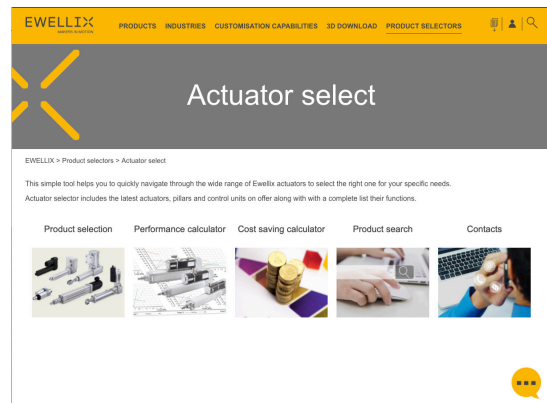

Publications

Supporting documents are available for download on ewellix.com on each product page under the technical data section:

- operating manual
- mounting instruction

Linear actuator CAHB series



High performance actuator CASM-100





ewellix.com

© Ewellix

All contents of this publication are the property of Ewellix, and may not be reproduced or given to third parties (even extracts) without permission. Although great care has been taken in the production of this catalog, Ewellix does not take any responsibility for damage or other loss resulting from omissions or typographical errors. The photo may differ slightly in appearance from the actual product. Due to continuous improvements being made in our products, the product's appearance and specifications are subject to change without notice.

PUB NUM EL-03013-EN-July 2022

Certain image(s) used under license from Shutterstock.com.
SKF and SKF logo are trademarks of the SKF Group